

Assembly Instructions

Rainwater Harvesting Model

Traveling Exhibit



RWH demonstration model developed by the Caribbean Environmental Health Institute (CEHI) for the Global Water Partnership Caribbean (GWP-C)

c/o NIHERST, 43-45 Woodford Street, Port of Spain, Trinidad.
Tel: (868) 622-3117; Fax (868) 622-1589; E-mail: info@gwp-caribbean.org; Web: www.gwp-caribbean.org

Table of Contents

	Page
Parts list	3
1. Bottom frame assembly	4
2. Top frame assembly	4
3. Vertical uprights assembly—lower	5
4. Roof assembly top frame	6
5. Roof assembly rafters	6
6. Roof assembly sheeting	7
7. Roof assembly ridgecaps	7
8. Vertical uprights assembly—upper	8
9. Roof installation	9
10. Skin installation	10
11. Pump and filter installation (a)	11
12. Pump and filter installation (b)	12
13. Rainfall simulator installation	13
14. First flush installation	14
15. Mounting interpretive panels	15
16. Complete assembly	16
17. Steps for operation	17

Parts list

Bottom frame sections X 3
Bucket X 1
Canvas skin X 1
First flush diverter brace (wood) X 1
First flush diverter X 1
First flush diverter tap X 1
First flush outflow cross pipe X 1
First flush outflow downpipe X 1
Guttering section (loose) X 1
Laminated posters X 4
Magazine/brochure stand X 1
Piping - stop valve section X 1
Piping - rainfall simulator - lower section X 1
Piping - rainfall simulator - upper section X 1
Pump (115 volts) X 1
Plastic clips X 9
Rafter assembly (wood) X 1 (pre-assembled)
Roof sheets X 9
Roof ridge caps X
2 and 3" Bolts with wingnuts X 20
Toggle bolts X 10
Top frame combined faciaboard X 3
Tank X 1
T connector - bottom X 1
T connector - top X 1
U clip X 1
Vertical uprights - lower sections X 7
Vertical uprights - top sections X 7
Vinyl interpretive panels X 7
Strapping
Water filter attachment plate (clear plastic) X 1
Water filter - cloth X 1
Water filter - charcoal X 1

Important: Keep screws in positions and replace the toggle bolts and wingnuts after disassembly to avoid loss. Keep other small loose components such as clips and other screws and nuts in the bag pouches in the carrying cases.

1. Bottom frame assembly

NOTE: the numbers (e.g. 4H) correspond to connection positions that are etched into the ends of the parts for guidance in assembly.

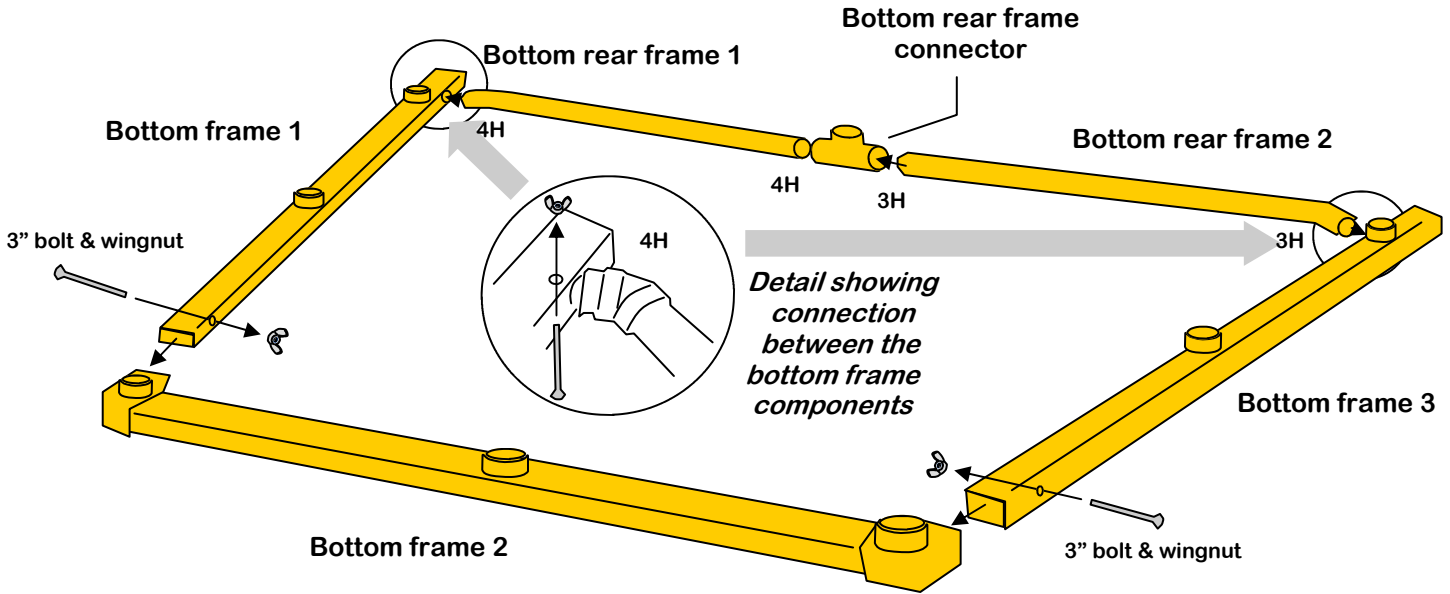

2. Top frame assembly

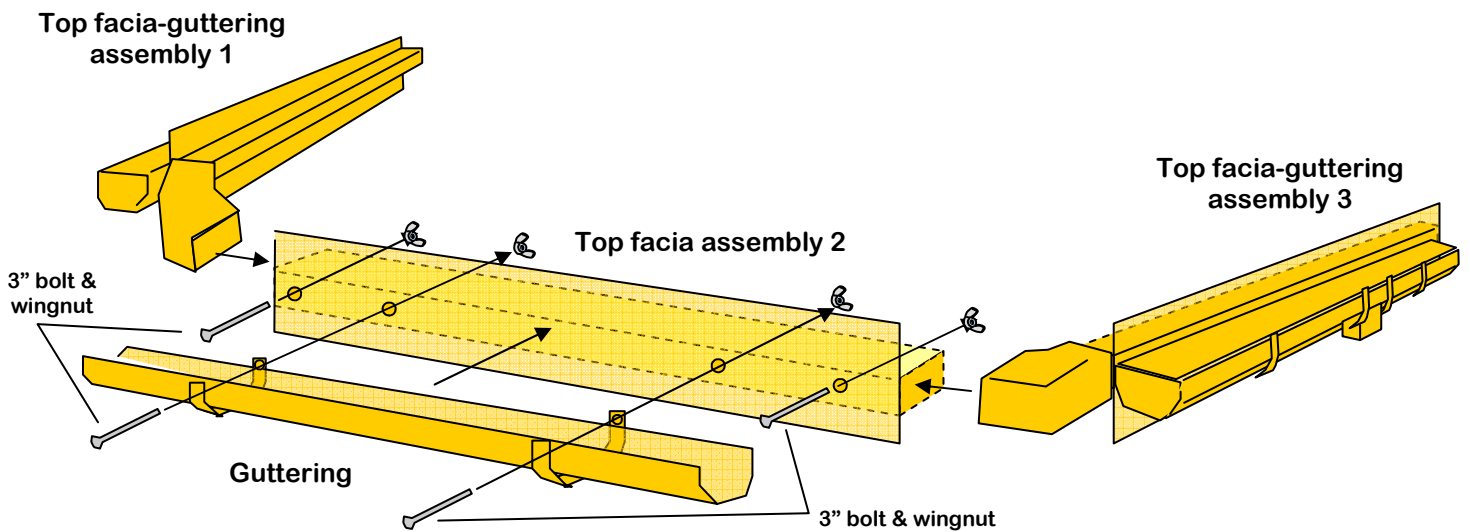

3. Vertical uprights assembly - lower

NOTE: the numbers (e.g. 4B) correspond to connection positions that are etched into the ends of the parts for guidance in assembly.

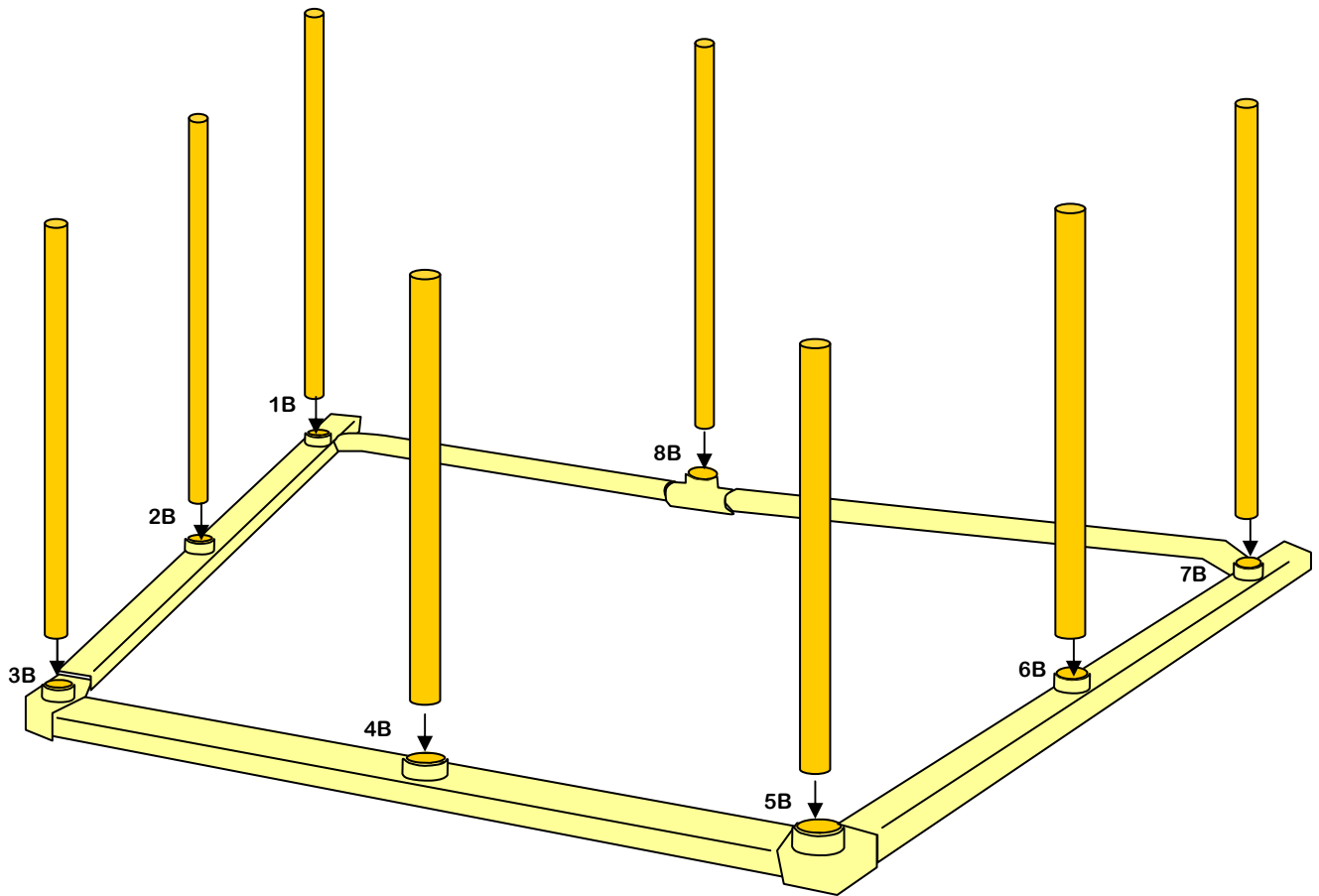

4. Roof assembly - top frame

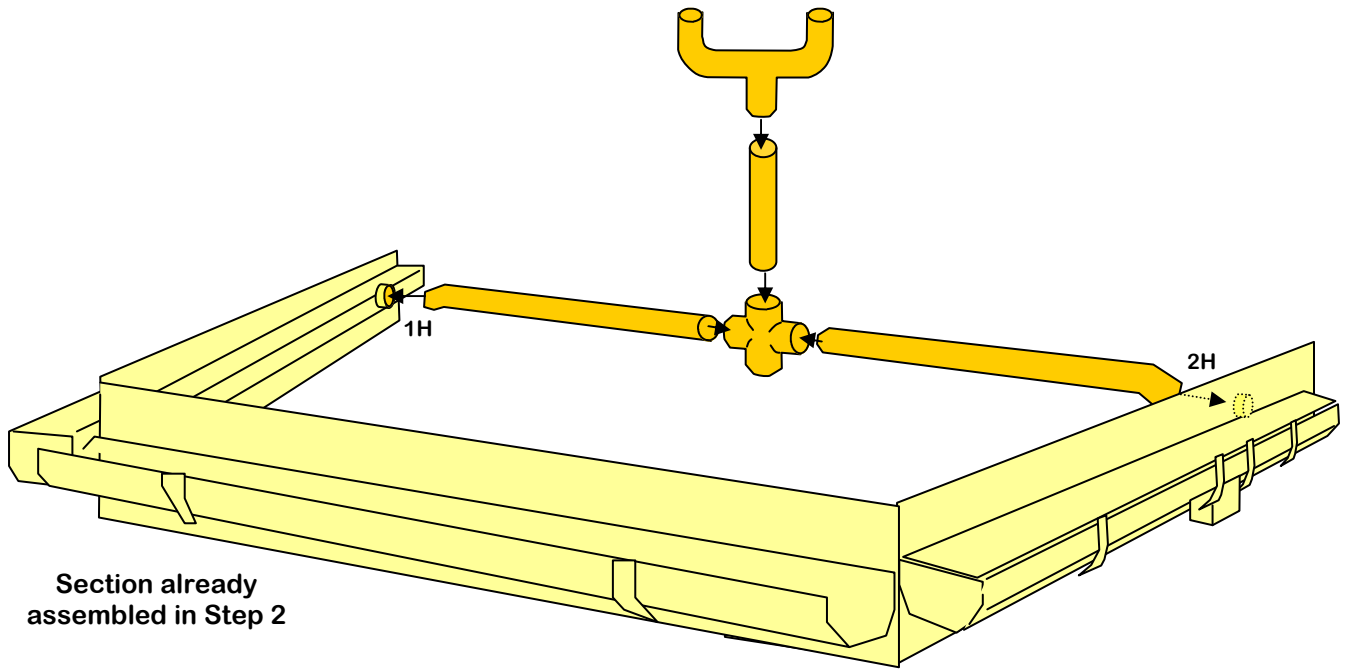

5. Roof assembly - rafters

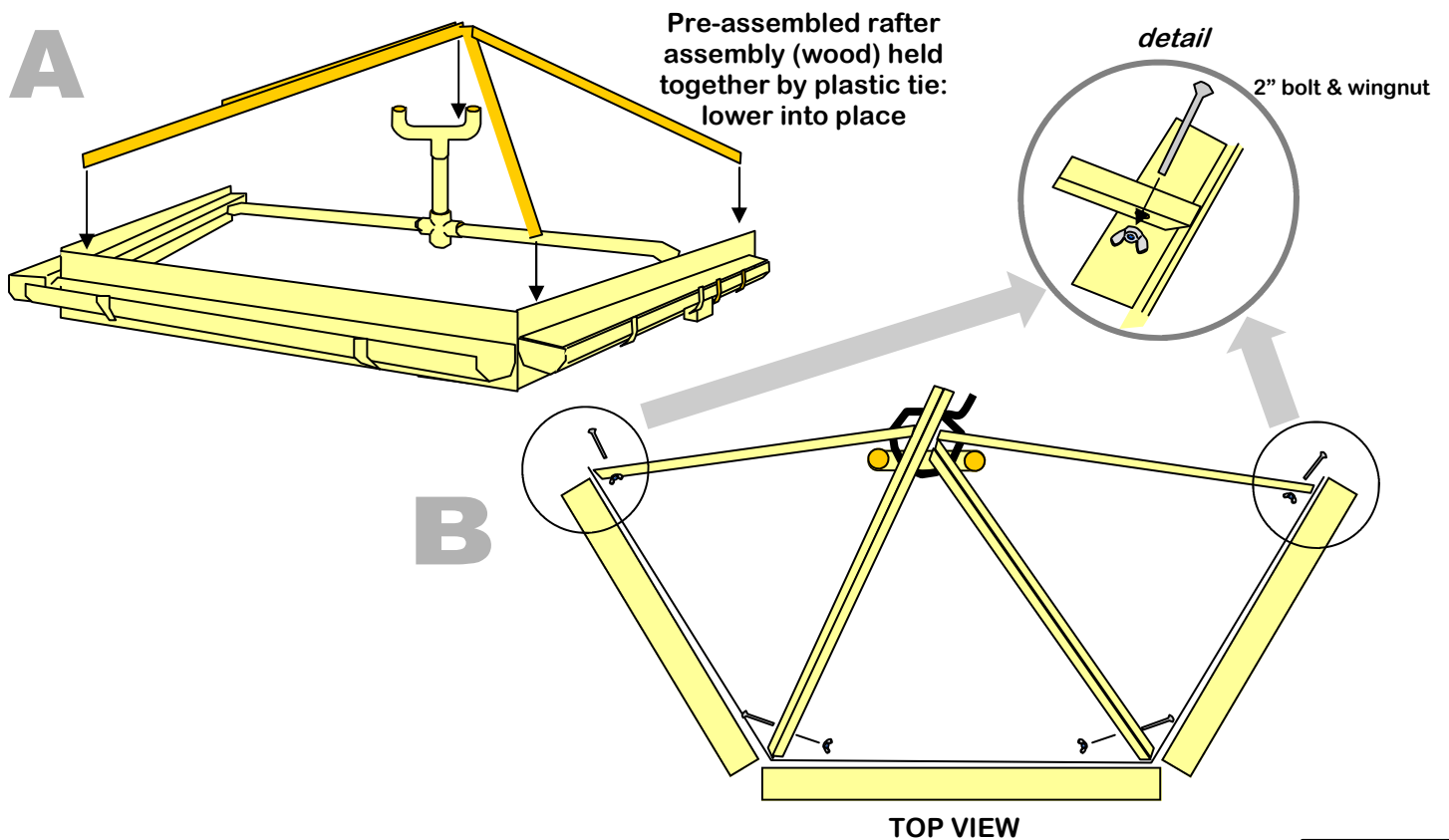

6. Roof assembly - sheeting

NOTE: the numbers on the individual roof sections are to guide installation as there are slight variations in dimensions of the right and left hand sections

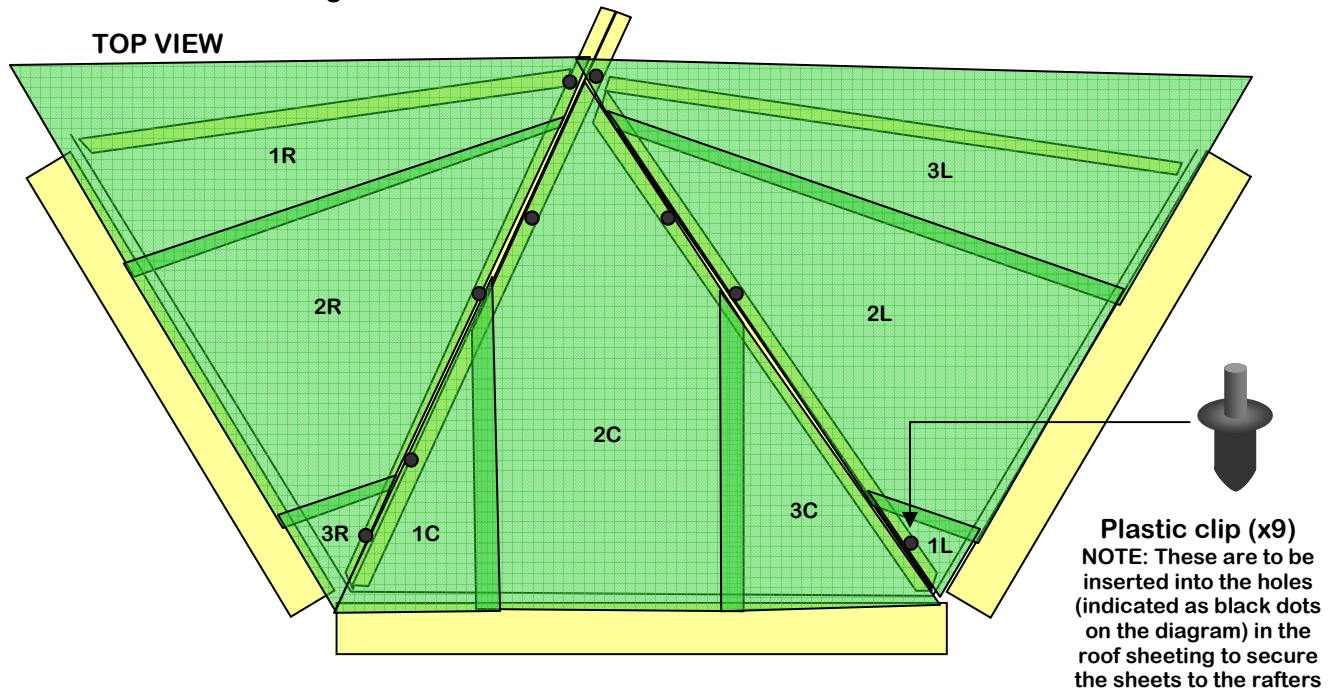

7. Roof assembly - ridgecaps

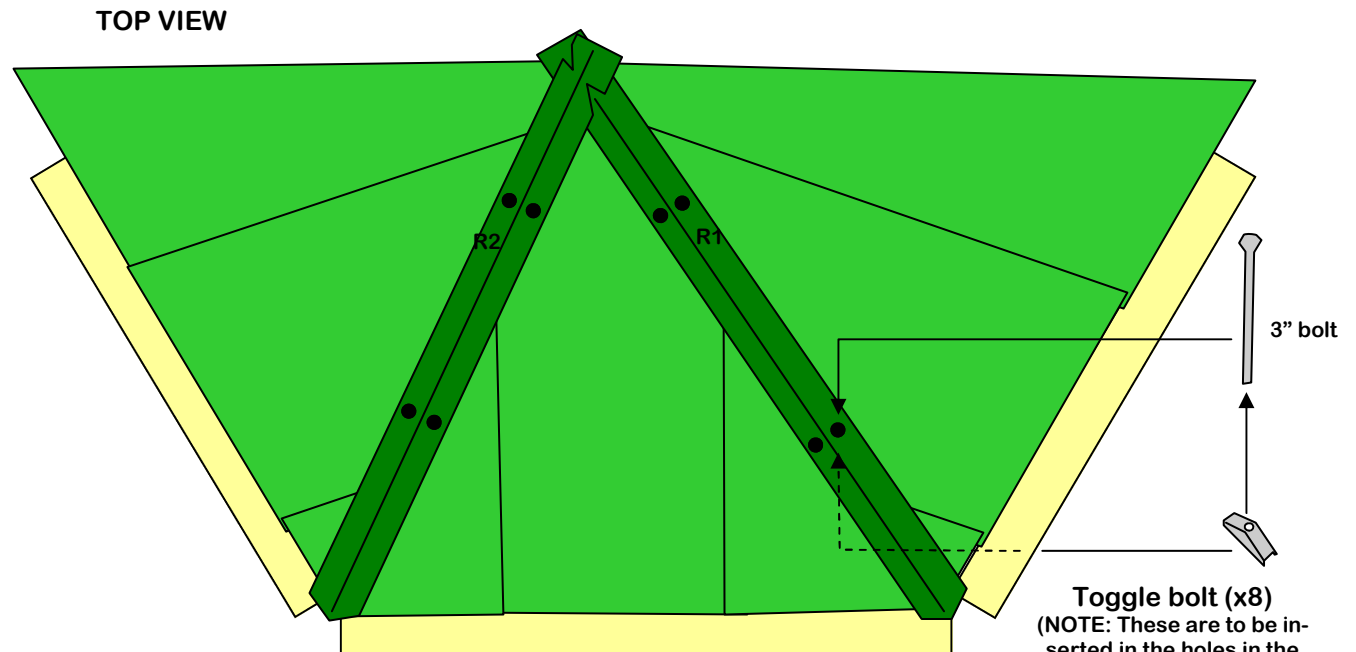

NOTE: ridgecap R1 is placed on first and R2 (which is notched at one end) is placed over R1 as shown

Toggle bolt (x8)
(NOTE: These are to be inserted in the holes in the ridgecaps; indicated as black dots on the diagram)

8. Vertical uprights assembly - upper

NOTE: the numbers (e.g. 4T) correspond to connection positions that are etched into the ends of the parts for guidance in assembly.

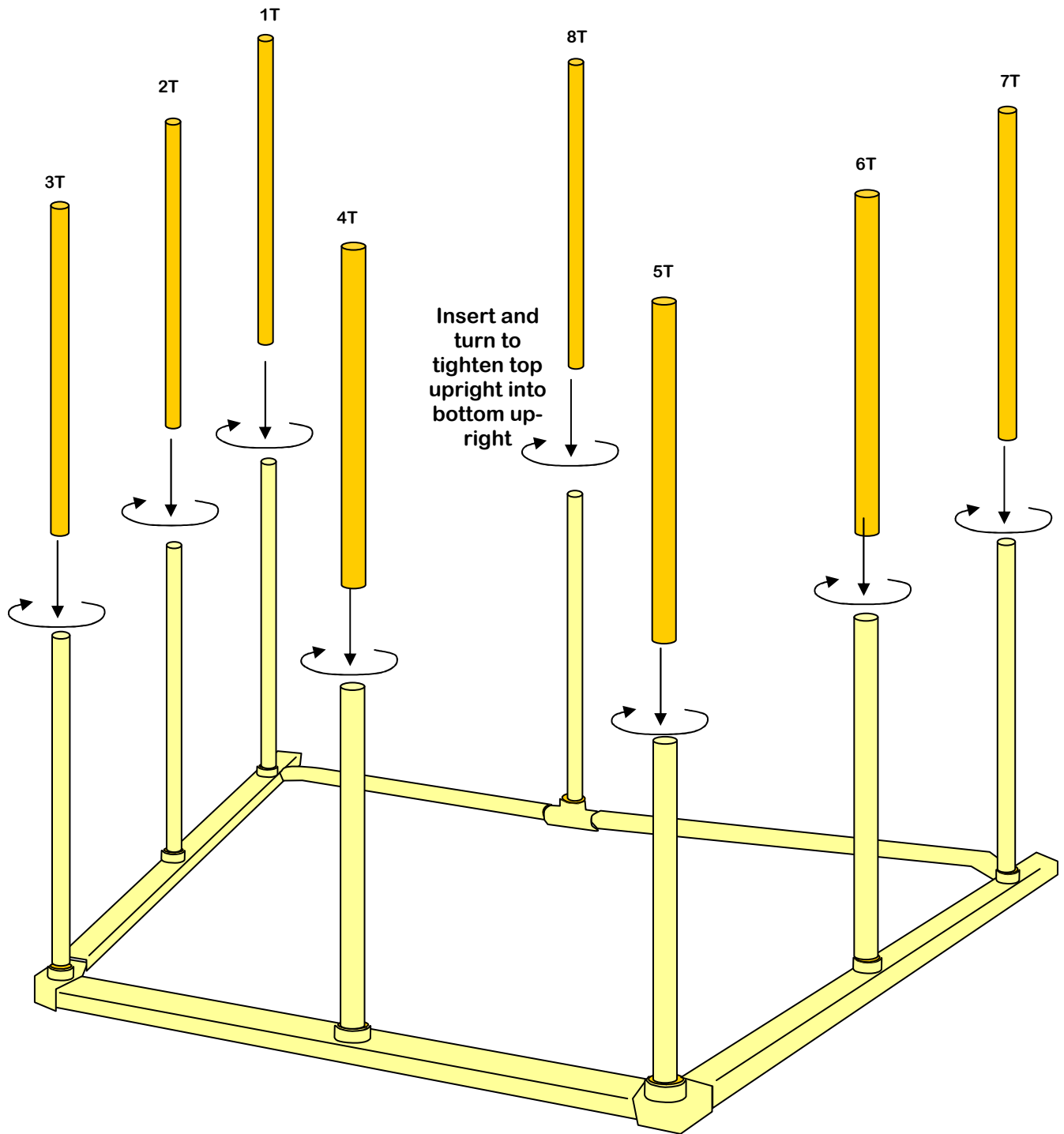

9. Roof installation

Lift roof section (assembled at end of Step 7) and lower on to the uprights. Align the corner uprights first to the receiving ports in the fascia/guttering assemblies. Follow by guiding in the middle uprights.

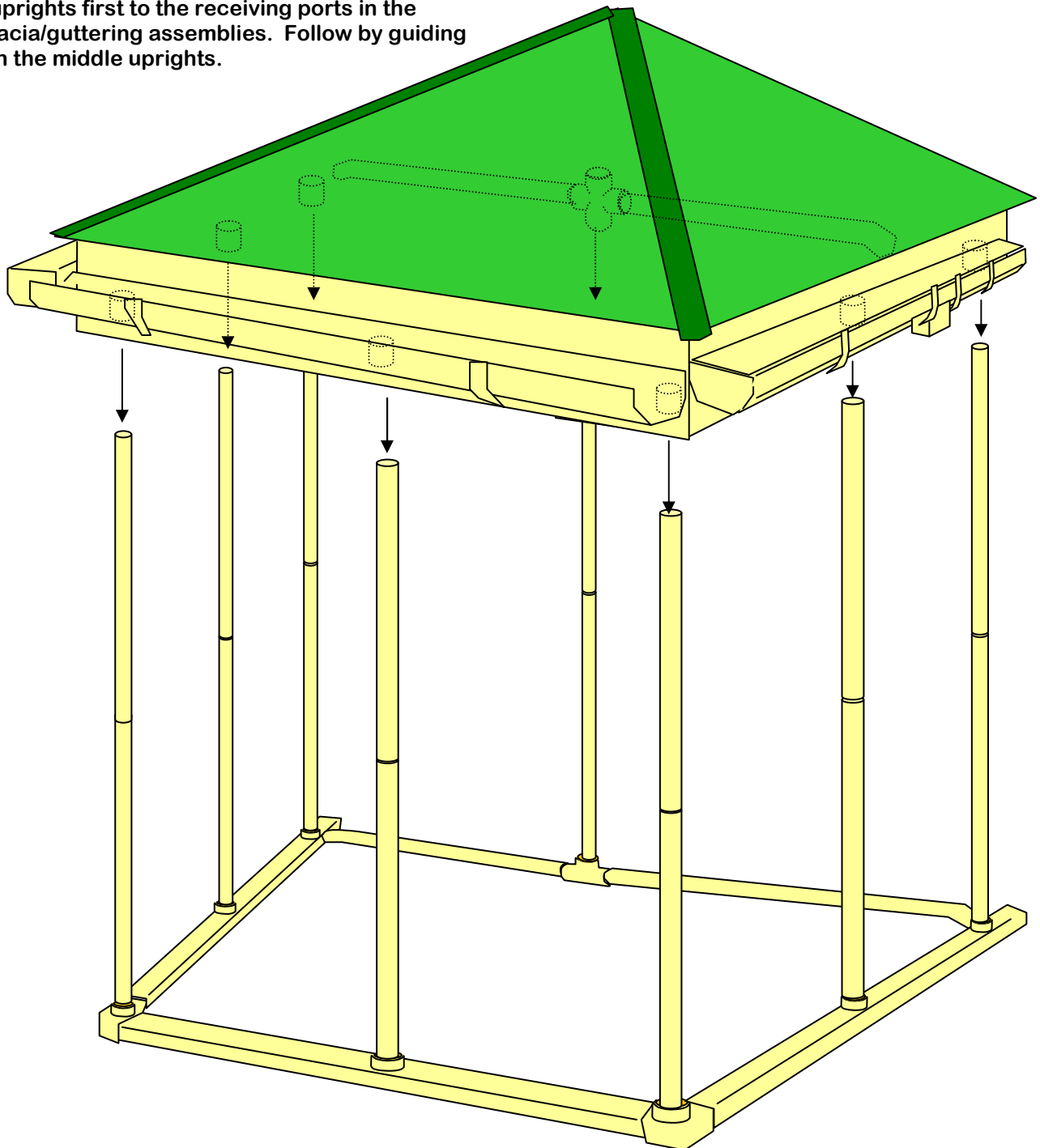

10. Skin installation

Pull canvas skin tightly over the uprights.
NOTE: Tuck the top edge of the skin within the inside of the faciaboard so that it is held by the Velcro strips affixed to the faciaboard.

TOP REAR CORNER:
Ensure the corner with the strapping is positioned snugly along the inside of the faciaboard and held securely by the Velcro strip.

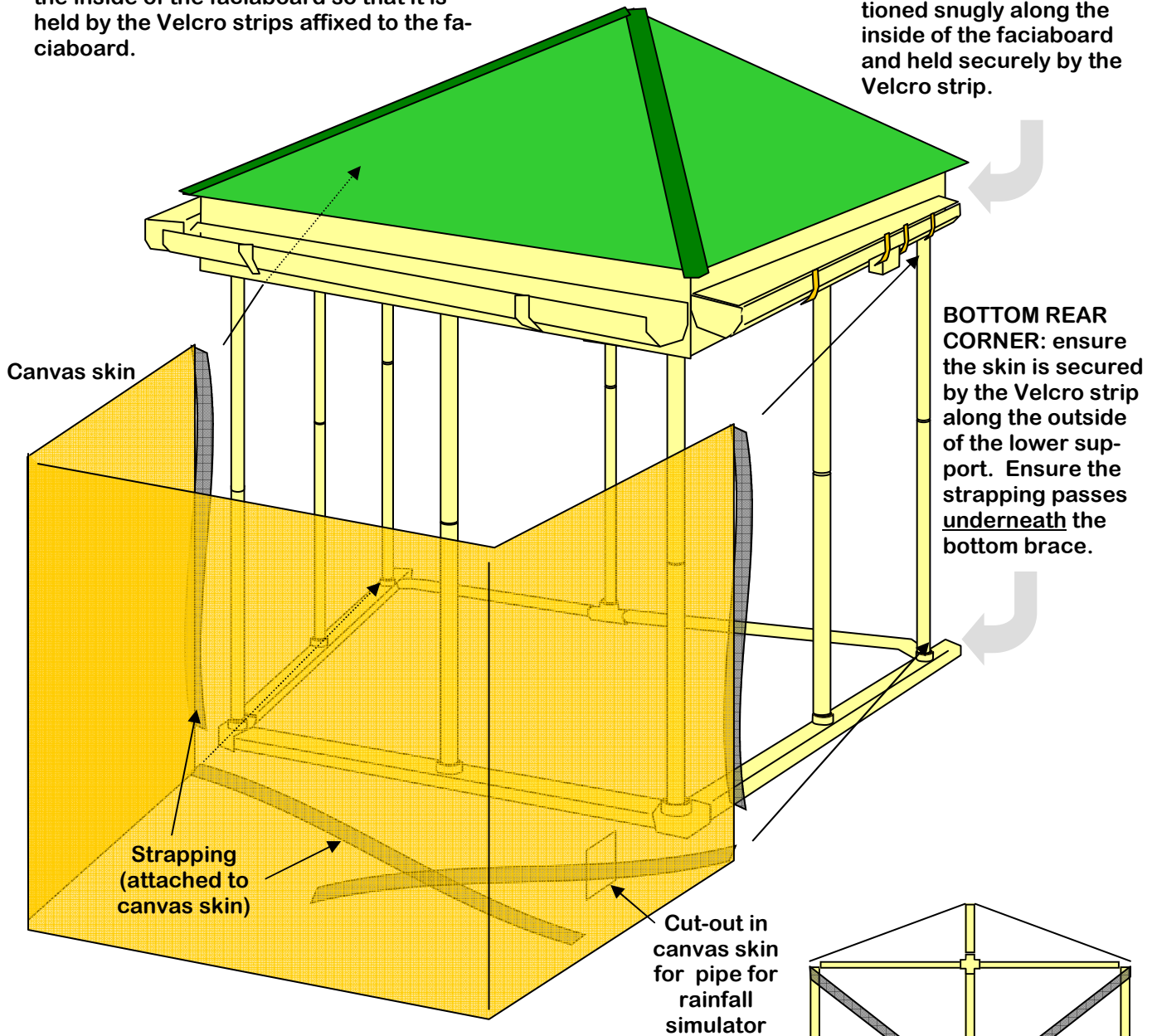

Wrap strapping once around centre upright. Adjust the buckles on the strapping to tighten to provide rigidity to the frame

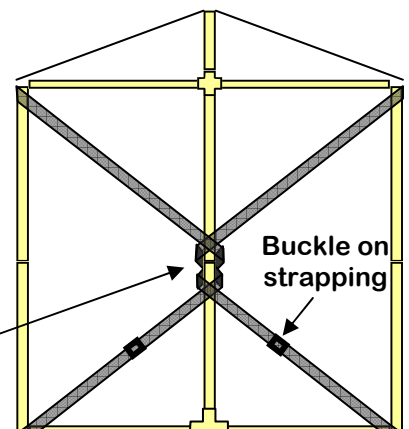

11. Pump and filter installation (a)

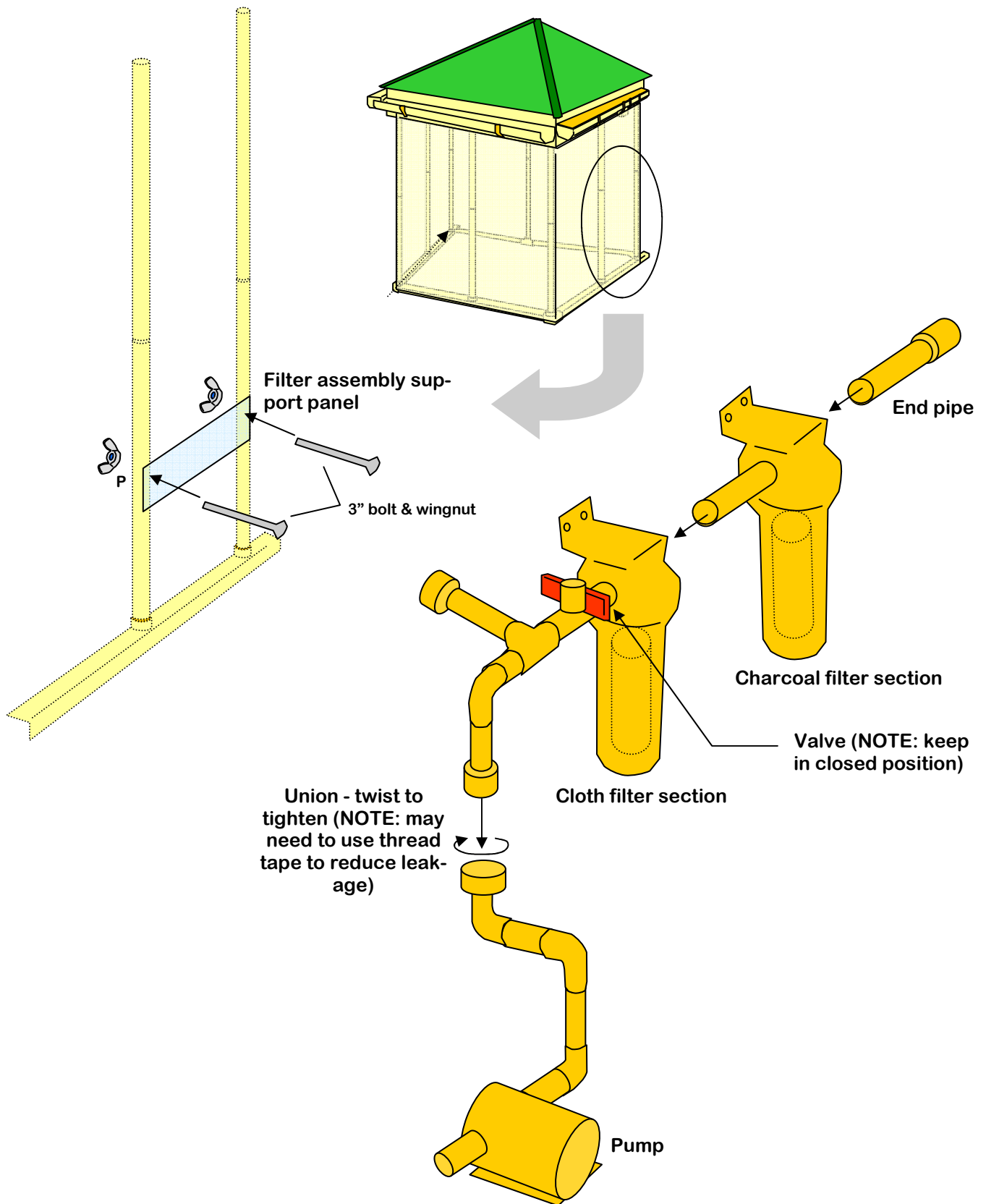

12. Pump and filter installation (b)

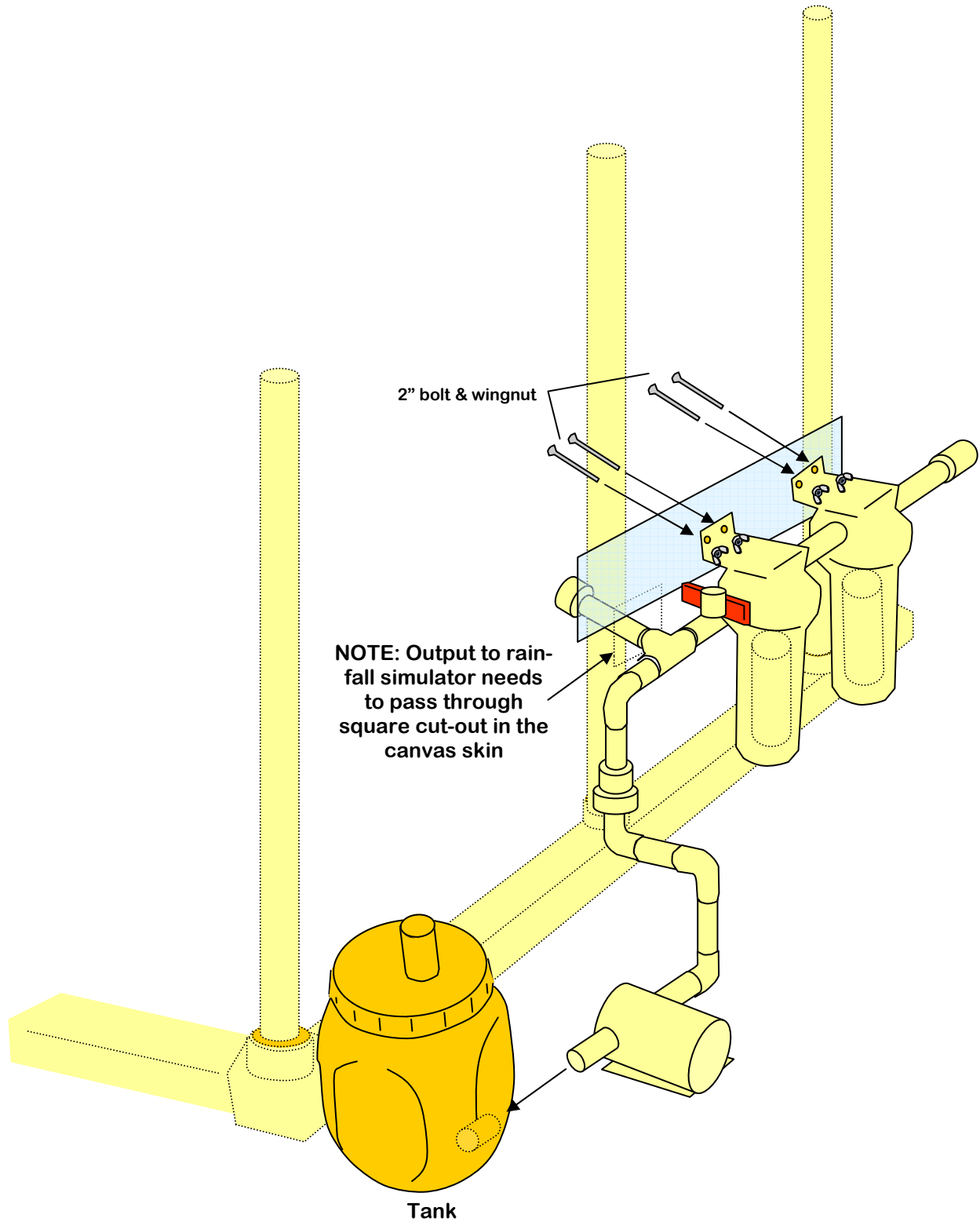

13. Rainfall simulator installation

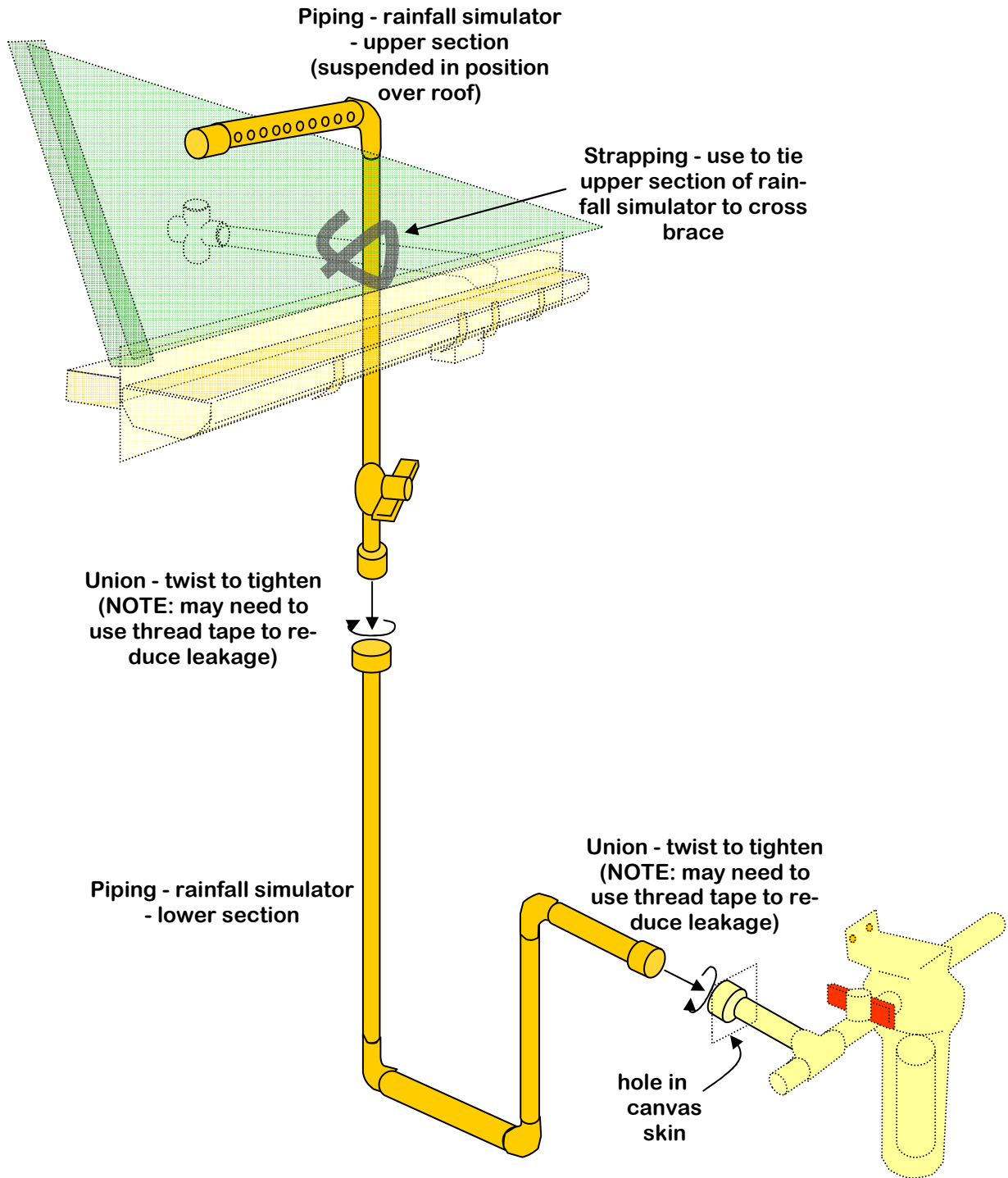

14. First flush installation

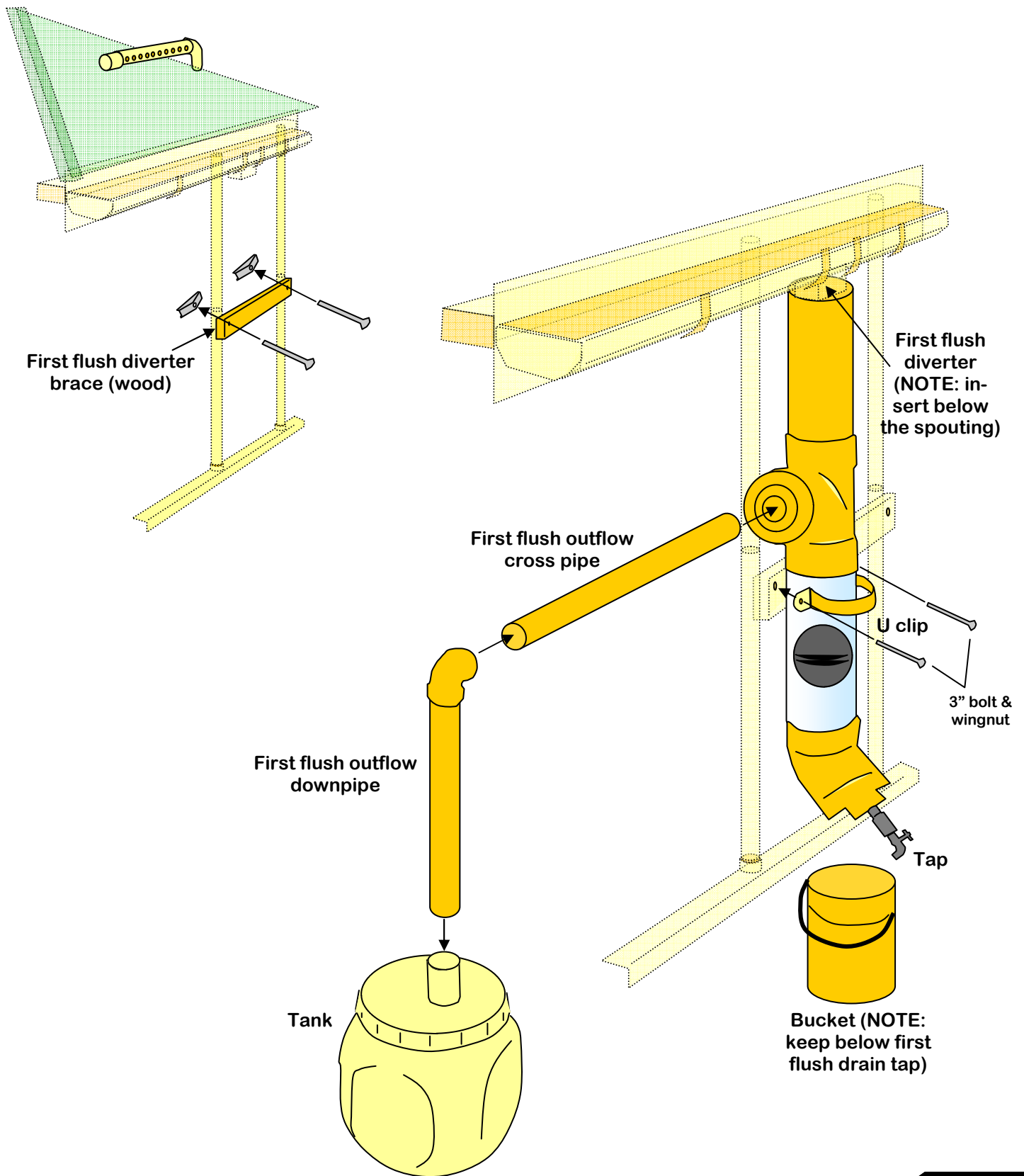

15. Mounting interpretive panels



RIGHT MODEL PANEL



CENTRE MODEL PANEL

The canvas skin has 'male' Velcro stitched on to it. The interpretive panels have the 'female' Velcro affixed on to the backs of the panels. Align the panels appropriately to the male receiving Velcro strips. The graphics illustrate the suggested arrangements of the interpretive panels on the canvas.

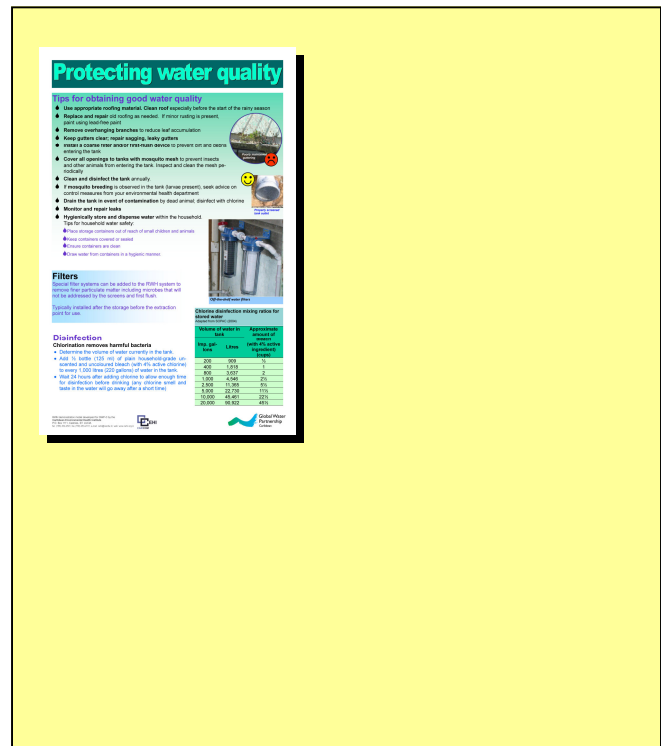

LEFT MODEL PANEL

Complete assembly

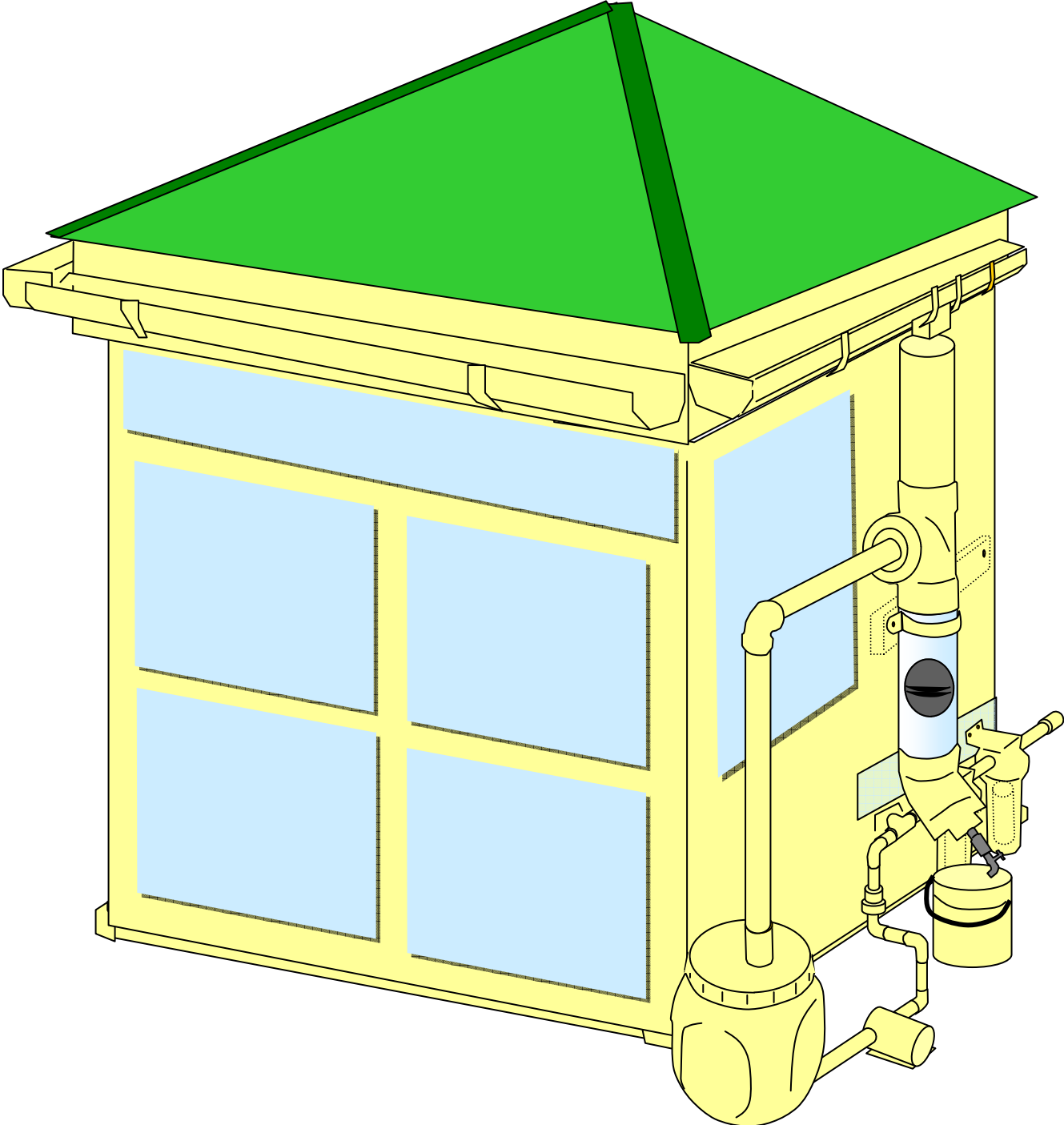

Steps for operation

1. Fill the tank with at least 3 buckets of water
2. Place the bucket under the drain tap of the first flush diverter to capture drippings
3. Ensure that all the unions are tightly secured. Thread tape may be used to improve the seal to prevent leakage.
4. Plug in pump and turn on. **NOTE: THE PUMP IS 115 VOLTS**
5. Allow the first flush diverter to fill with water (the float ball will rise in the down-pipe column stopping at a constriction just below the T connector)
6. The overflow from the first flush will return back to the tank and cycle through the model as long as the pump remains on, however it is recommended that once the first flush diverter is filled (the float ball stops rising) the pump is turned off.
7. To repeat the demonstration open the tap of the first flush diverter and drain out the water into the bucket. Close the tap once all water has been drained. Open the lid of the tank and return the water in the bucket to the tank.
8. Repeat the demonstration.

Questions? Contact:

Global Water Partnership Caribbean at:

c/o NIHERST,
43-45 Woodford Street, Newtown,
Port of Spain,
Trinidad & Tobago
Tel: +868-622-3117
Fax: +868-622-1589
E-mail: info@gwp-caribbean.org
Website: www.gwp-caribbean.org



Caribbean Environmental Health Institute at:

P.O. Box 1111
The Morne,
Castries
St. Lucia
Tel: +758-452-2501
Fax: +758-453-2721
E-mail: cehi@candw.lc
Website: www.cehi.org.lc

